

PIANTA (PLAN)

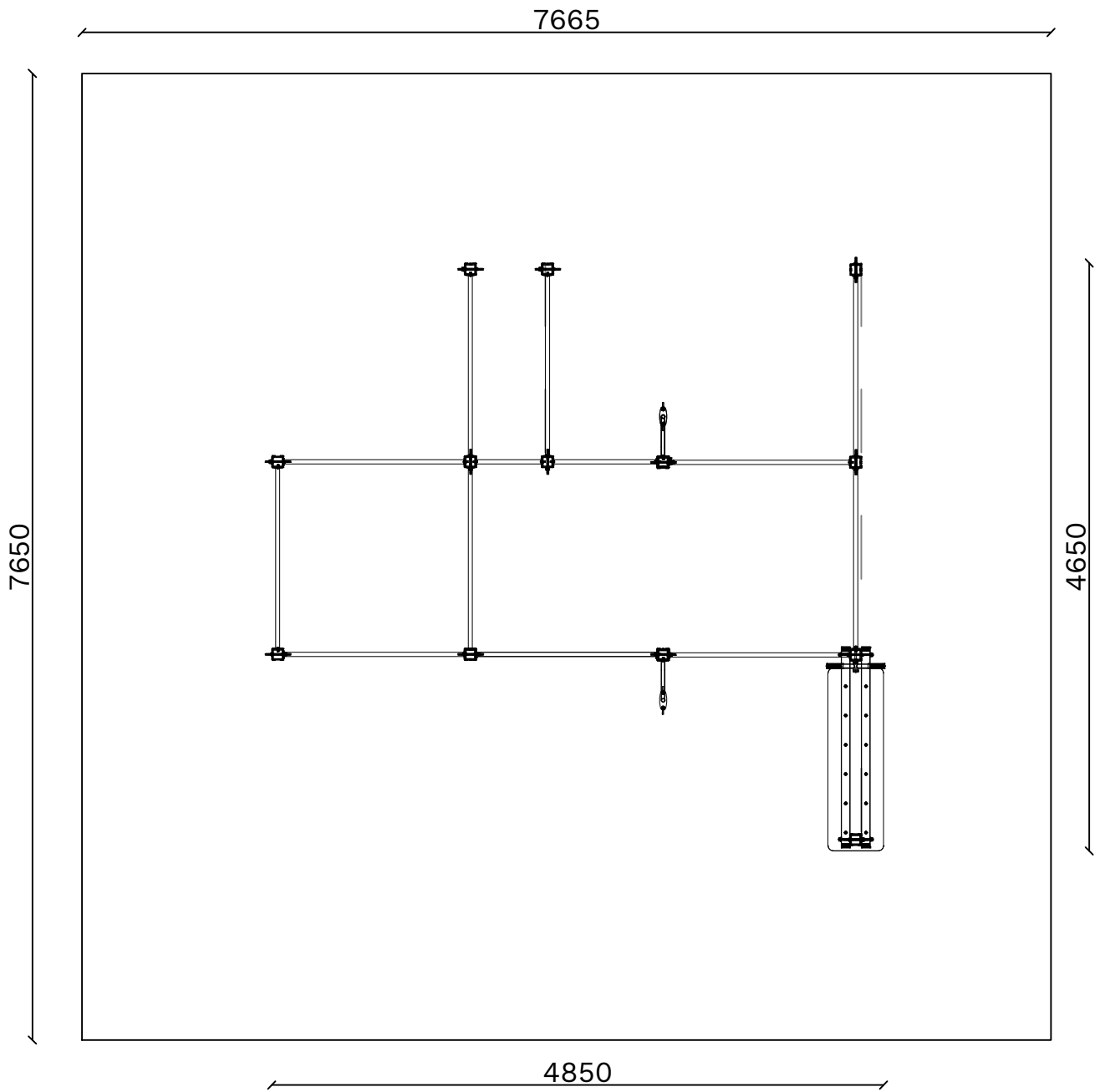

AREA DI SICUREZZA (SAFETY AREA) 59MQ

SCHEDA TECNICA (TECHNICAL DATA SHEET)

ART. T01005_ALX | 04-06-2024 | SCALA (SCALE) 1:50

LE MISURE SONO ESPRESSE IN MM. (MEASUREMENTS ARE EXPRESSED IN MM.)



TIEGI SRL
 VIA BENEDETTO CROCE 7
 Z.I. "CONDOTTI BARDINI"
 31058 SUSEGANA (TV)
 0438-460519

L LL LL LL LL LL L L L L

FOGLIO 2 DI 6

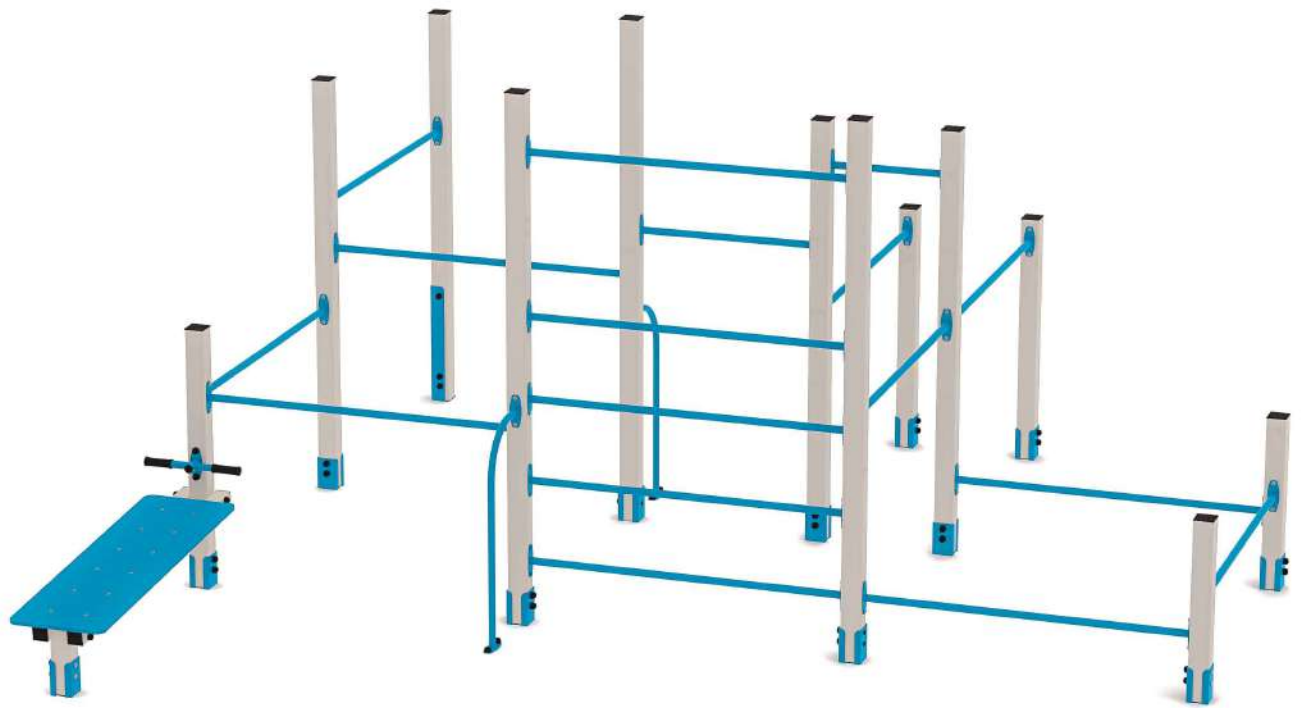

ALTEZZA DI CADUTA MAX. (HIC)
<150 cm



INGOMBRO (OVERALL DIMENSION)
485 cm x 465 cm x 241 cm H.



NUMERO UTILIZZATORI 11
(MAX N. OF SIMULTANEOUS USERS)



AREA DI SICUREZZA (SAFETY AREA)
765 cm X 767 cm



SUPERFICIE ANTITRAUMA 59 mq
(SAFETY SURFACING AREA)



ALTEZZA D'USO (USE HEIGHT)
> 140 cm

SCHEDA TECNICA (TECHNICAL DATA SHEET)

ART. T01005_ALX

04-06-2024

SCALA (SCALE)

LE MISURE SONO ESPRESSE IN MM. (MEASUREMENTS ARE EXPRESSED IN MM.)



TIEGI SRL
VIA BENEDETTO CROCE 7
Z.I. "CONDOTTI BARDINI"
31058 SUSEGANA (TV)
0438-460519

L L L L L L L L L L L L L L L L

FOGLIO 3 DI 6

**PALO IN ALLUMINIO CON ANGOLI
ARROTONDATI DA 90X90 MM LACCATO A
POLVERE, DOTATO DI STAFFA PER
ANCORAGGIO AL TERRENO O CLS**

*(90X90 MM POWDER-COATED ALUMINIUM POLE WITH ROUNDED
CORNERS, EQUIPPED WITH BRACKET FOR ANCHORING TO THE
GROUND OR CONCRETE)*

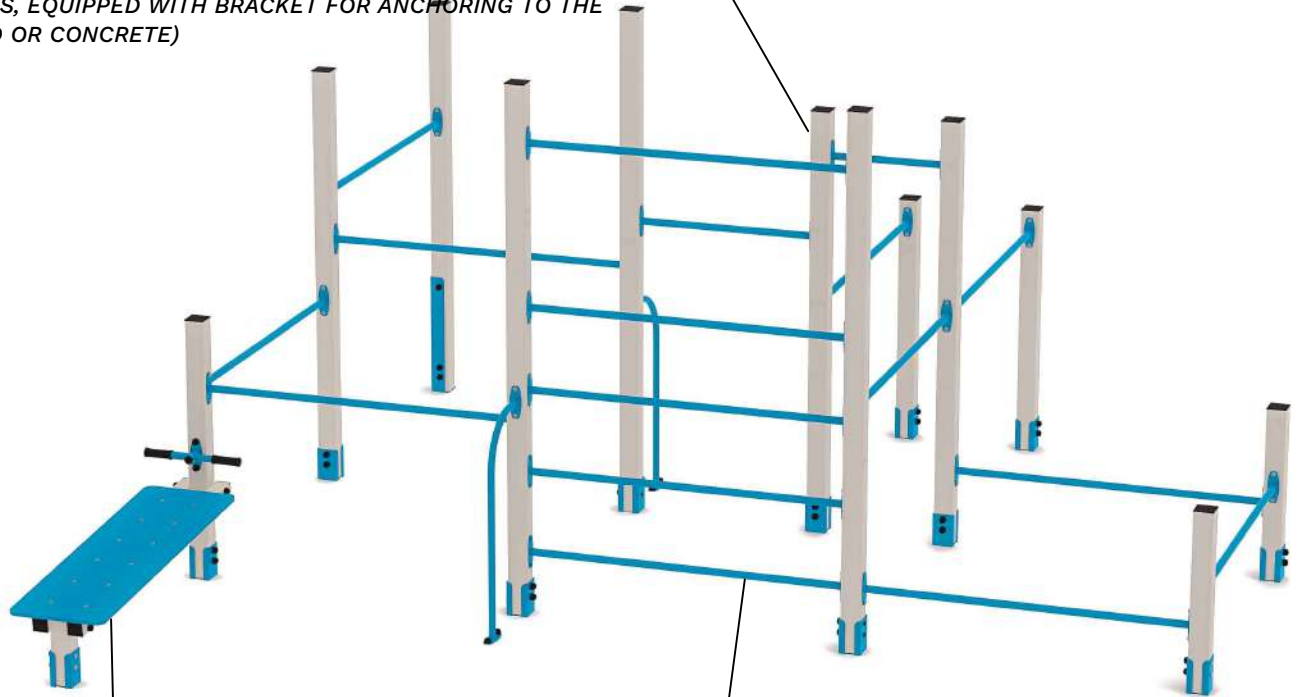

**PIANO PER ESERCIZI IN
HDPE SANDWICH CON
MANIGLIE IN POLIETILENE**
*(HDPE SANDWICH EXERCISE SURFACE
WITH POLYETHYLENE HANDLES)*

**TUBI 33X3MM
LACCATI A
POLVERE** *(TUBES
33X3MM
POWDER-COATED)*

**TUTTI GLI ELEMENTI DI FISSAGGIO, VITI, DADI,
RONDELLE ECC. SONO IN ACCIAIO ZINCATO E
PROTETTI DA GHIERE E TAPPI IN POLIETILENE**
*(ALL FASTENERS SCREWS, NUTS, WASHERS ETC. ARE MADE OF GALVANISED
STEEL AND PROTECTED BY POLYETHYLENE FERRULES AND CAPS)*

SCHEMA TECNICA (TECHNICAL DATA SHEET)

ART. T01005_ALX | 04-06-2024 | SCALA *(SCALE)*

LE MISURE SONO ESPRESSE IN MM. *(MEASUREMENTS ARE EXPRESSED IN MM.)*



TIEGI SRL
VIA BENEDETTO CROCE 7
Z.I. "CONDOTTI BARDINI"
31058 SUSEGANA (TV)
0438-460519

L L L L L L L L L L L L L L L L

FOGLIO 4 DI 6

VISTA FRONTALE (FRONTAL VIEW)

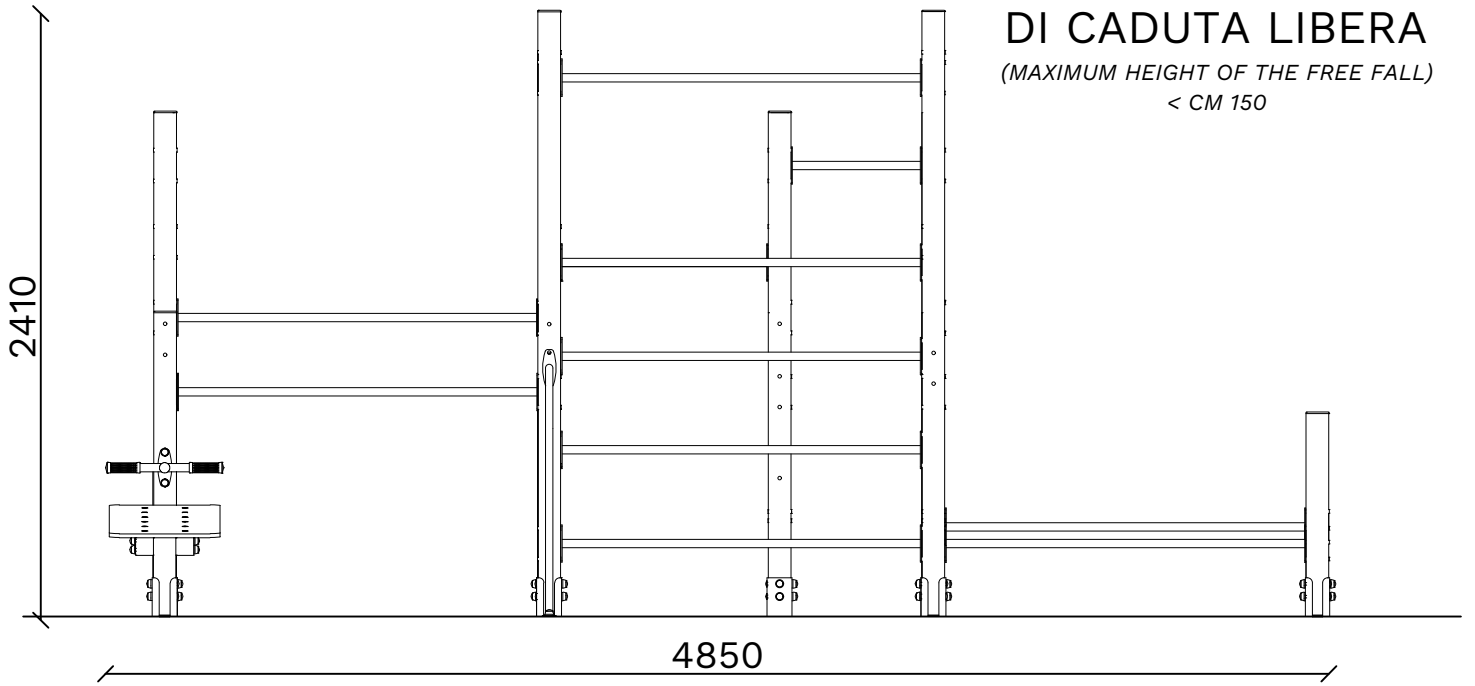

VISTA LATERALE (LATERAL VIEW)

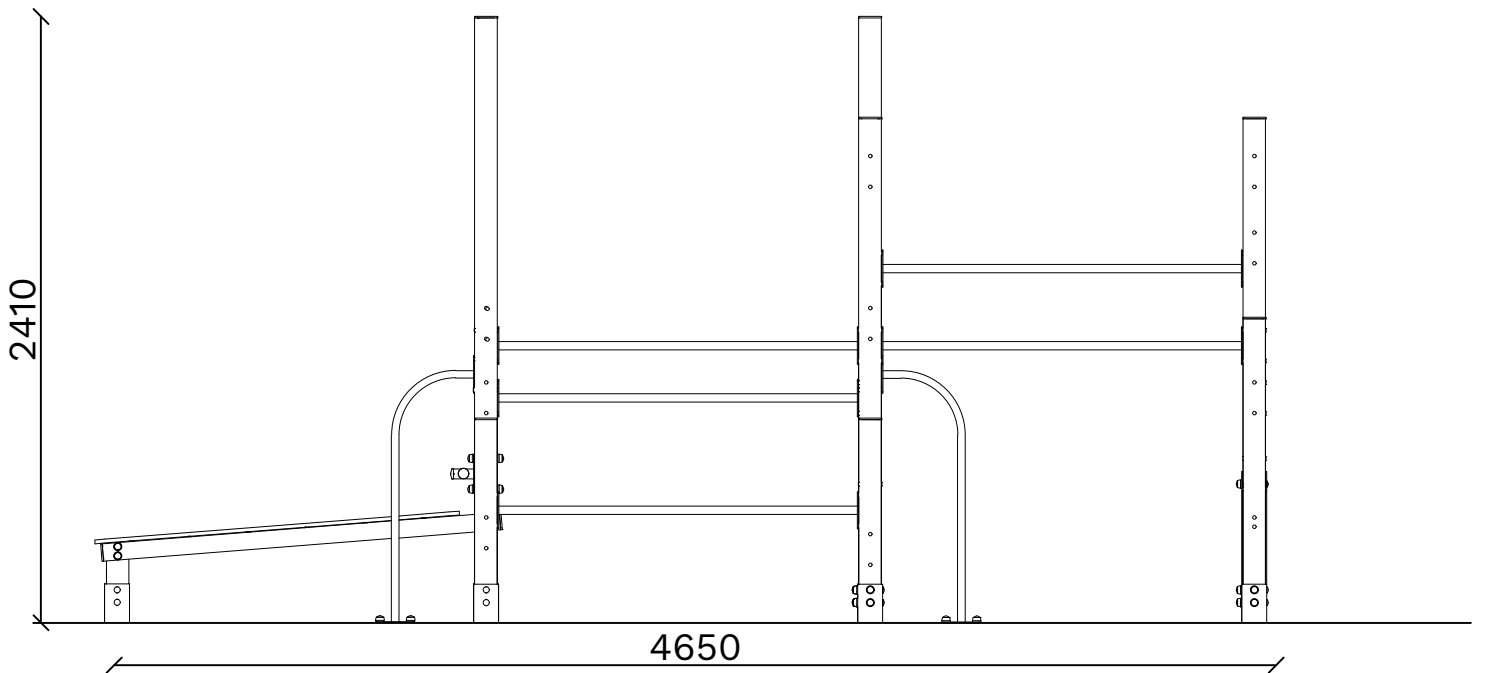

INGOMBRO MAX (OVERALL DIMENSIONS)

SCHEMA TECNICA (TECHNICAL DATA SHEET)		
ART. T01005_ALX	04-06-2024	SCALA (SCALE) 1:30
LE MISURE SONO ESPRESSE IN MM. (MEASUREMENTS ARE EXPRESSED IN MM.)		
	TIEGI SRL VIA BENEDETTO CROCE 7 Z.I. "CONDOTTI BARDINI" 31058 SUSEGANA (TV) 0438-460519	FOGLIO 5 DI 6
L L L L L L L L L L L L L L L		

